

AGES
5+
YEARS



3 IN 1 COMBO GAMES TABLE

Instruction Sheet



ambassador

Manufactured by:
Merchant Ambassador (Holdings) Ltd.,
Room 2502, 25/F, Perfect Industrial Building, 31 Tai Yau Street,
San Po Kong, Kowloon, Hong Kong

MADE IN CHINA

For product support, missing or broken parts,
and other issues & questions, please contact us through the
customer care section of our website www.ambassadorgames.com
or email Info@merchantambassador.com
ambassador™ is a trademark of Merchant Ambassador (Holdings) Ltd.
All Rights Reserved.

16696











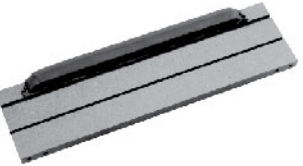

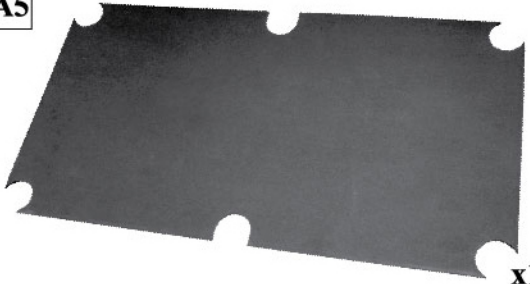
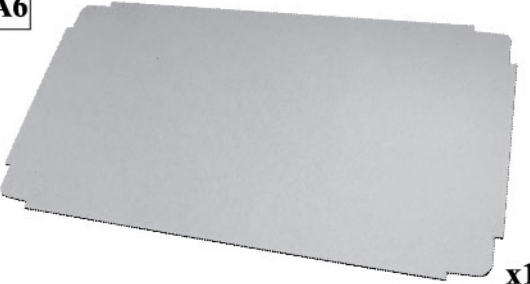



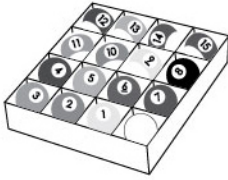



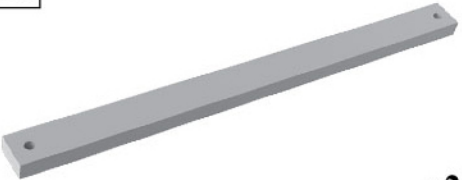

Item no.# MA8180

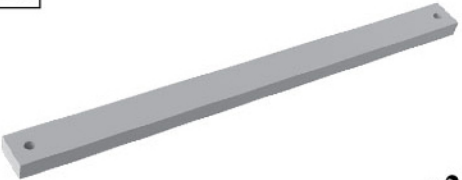

Assembly Video scan above or go to:
<http://www.ambassadorgames.com/assemblyvideos>

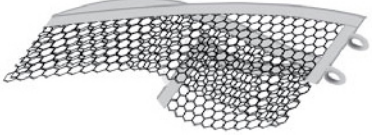
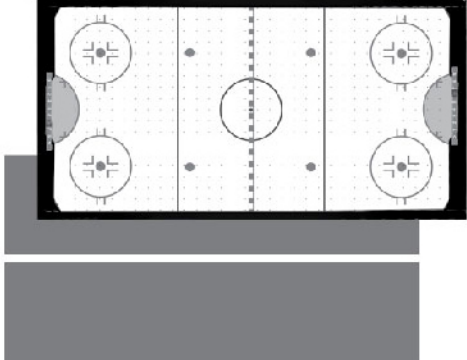
Keep this information.
Adult assembly required.
WARNING! Not suitable for children under 3 years.
Choking hazard. Small balls. Small parts.
Colour, designs and decorations may vary from those shown in photographs.
For indoor use only.

PARTS LIST

A1  x1	A2  x1	A3  x1 A4  x1			
A5  x1	A6  x1	A7  x4 A8  x4			
A9  x1	A10  x1	A11  x1	A12  x4	A13  x4	A14  x4
A15  x2	A17  x2				
A16  x4	A17  x2				
B1  x2	B2  x2	B3  x2	B4  x1		
B5  x1	B6  x3	B7  x2 B8  x2			

ASSEMBLY INSTRUCTIONS

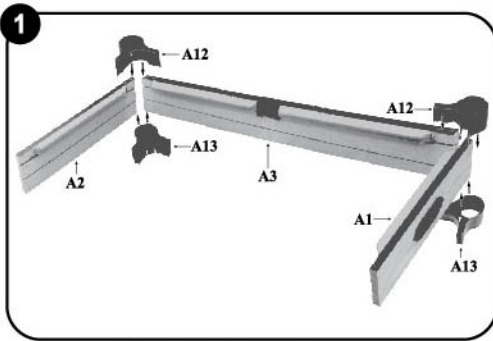

Attach long side (A3) and 2 small sides (A1 & A2) in a horizontal position with large (A13) and small (A12) corner pieces, making sure the grooves in the rails line up correctly as shown above in Diagram 1.

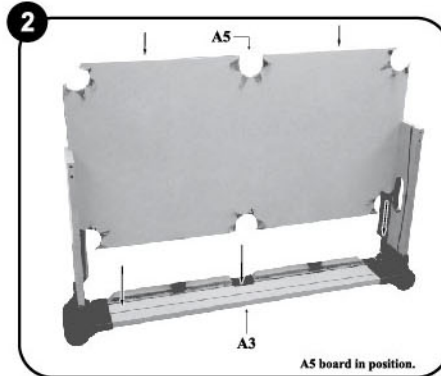

A5 board in position.

Slide board (A5) into upper grooves, closest to the bumpers, as shown above in Diagram 2. Make sure the felt side is facing towards the top of the games table.

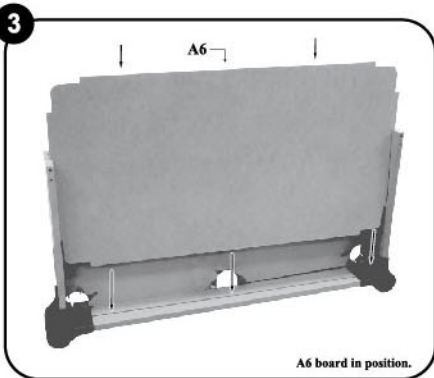
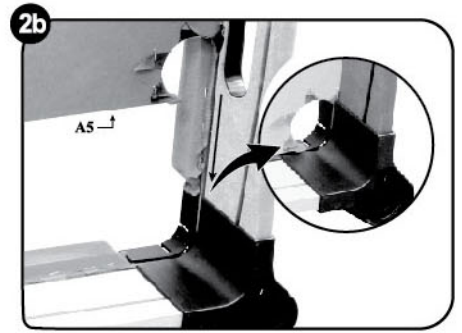

A6 board in position.

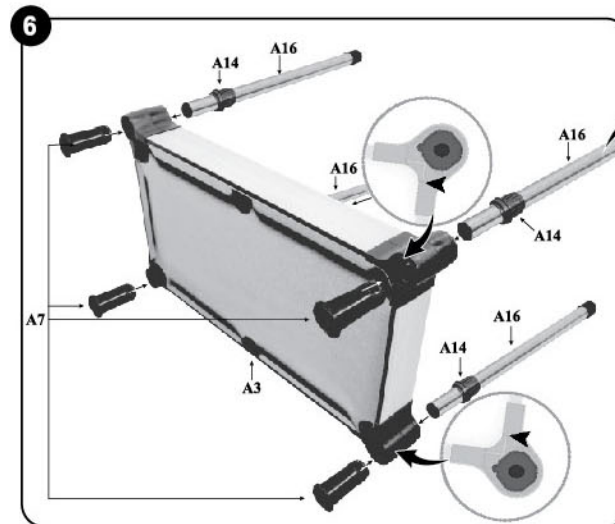
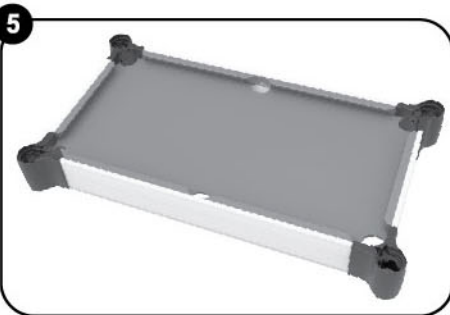
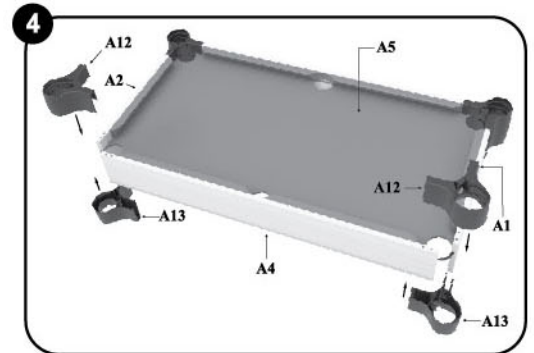
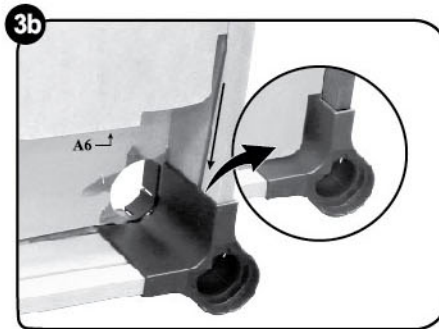

*For this step the table should still be resting on its long side board (A3) for easier assembly, as shown in Diagram 6. Press down on part A7 so it does not lift out of position while simultaneously pushing in the A16 steel leg until it reaches the full inner depth while screwing in part A14 nut. Throughout this step continue to intermittently push in the steel leg to ensure it is fully inserted into the cavity, before the A14 nut is fully fastened.

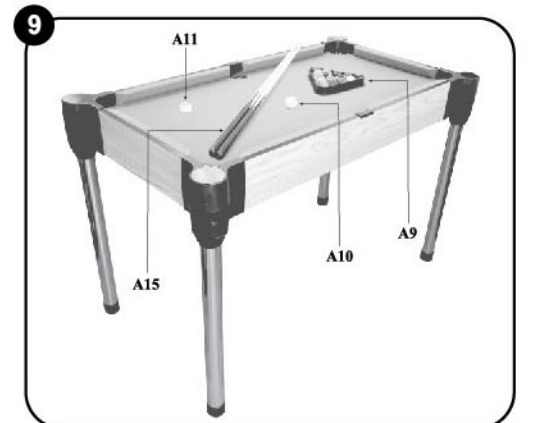
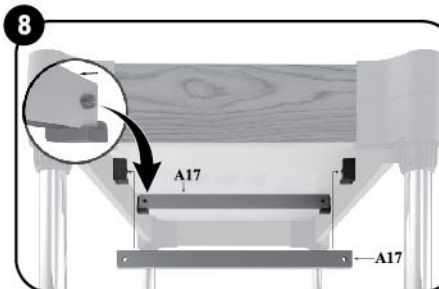
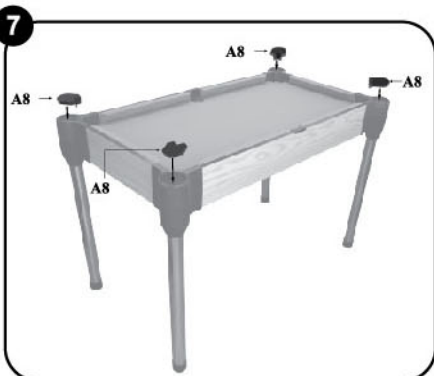

ASSEMBLY INSTRUCTIONS

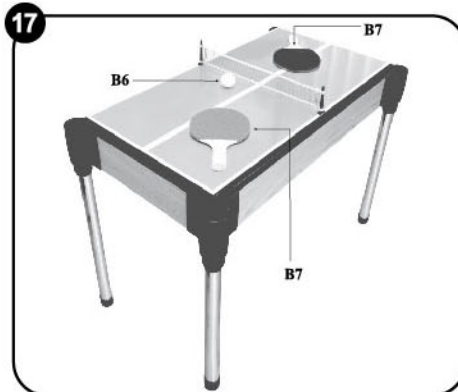
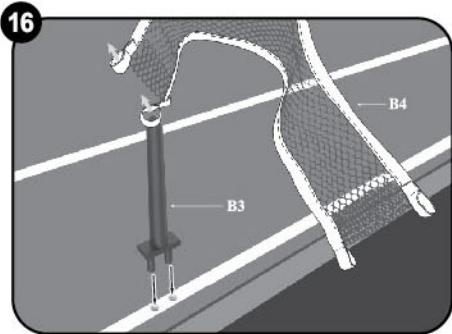
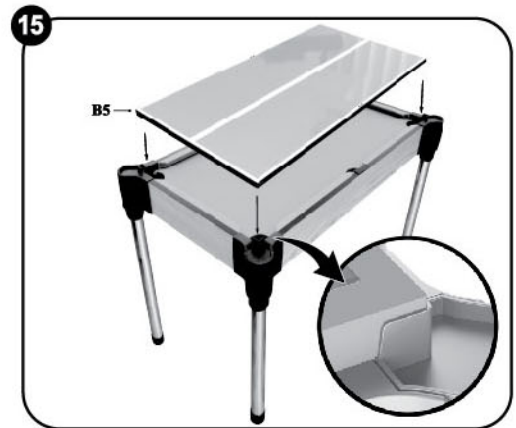
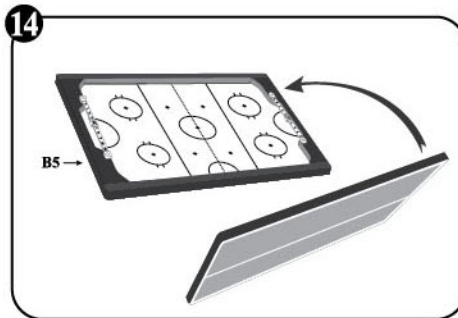
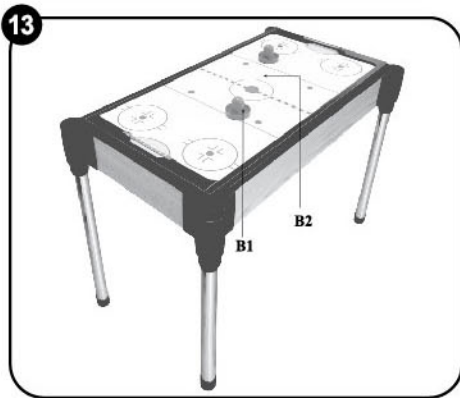
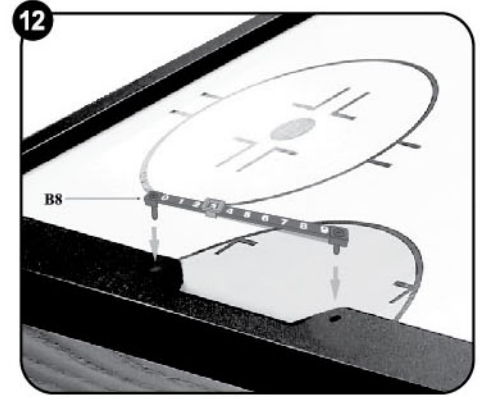
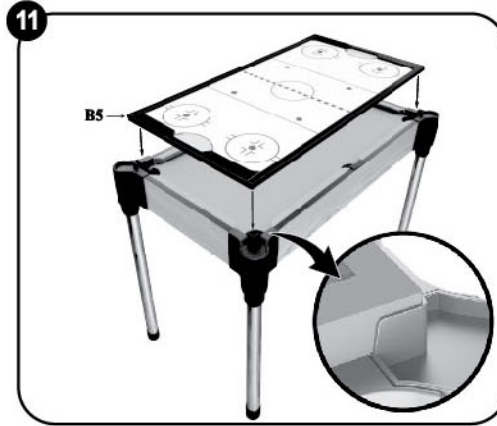
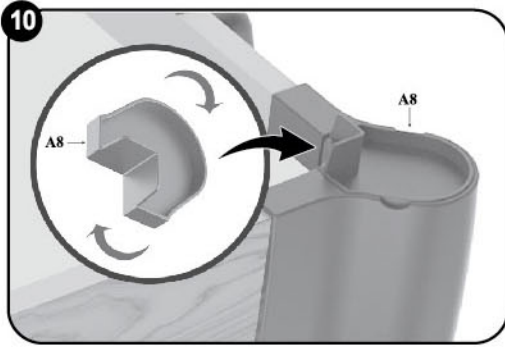

PING PONG (TABLE TENNIS) / GAME RULES

A game is started when one player (server) makes a service before the receiver makes the return.

The Server should:

- (1) Start with the ball resting freely on an open palm.
- (2) Project the ball near vertically upwards, without imparting spin.
- (3) Strike the ball so that it touches first his/her court and then, after passing over the net assembly, touches directly the receiver's court. In doubles, the ball must touch successively the right half court of server and receiver.

- (4) Once the ball has been served, both players are to make returns until a point is scored. In doubles, each player on the same team must take turns to make the return.

To Win:

After 2 points have been scored, the receiving player/pair shall become the serving player/pair and so on until the end of the game.

Scoring:

A set is when one of the players or pairs first scores 11 points. In the event that both players/pairs score 10 points, a set is won by the first player/pair to gain a 2-point lead. A full match is won when a player or pair wins the best of any odd number of sets (3,5,7).

A point is scored when:

1. An opponent fails to make a correct service.
2. An opponent fails to make a return.
3. The ball touches any part of an opponent's body.
4. An opponent strikes the ball twice in succession.
5. If an opponent, or anything an opponent wears, touches the playing surface or net during play.
6. If a doubles opponent strikes the ball out of the sequence established by the first server and first receiver.

TABLE POOL / GAME RULES

Assembly Instructions:

Follow the assembly instructions shown.

Object of the Game:

Eight-ball is played with sixteen balls: the white cue ball, and fifteen object balls numbered 1 through to 15, consisting of seven striped balls, seven solid balls and the black 8 ball. After the balls are scattered on a break shot, the players are assigned either the group of solid or striped balls, once a ball from a particular group is legally pocketed. The ultimate object of the game is to legally pocket the black 8 ball in a called pocket, which can only be done after all of the balls from a player's assigned group have been cleared from the table.

Set Up and Game Play:

To start the game, the object balls are placed in a triangular rack. The base of the rack is parallel to the end rail (the short end of the pool table) and positioned so the apex ball of the rack is located midway between the side and corner pockets. The balls in the rack are ideally placed so that they are all in contact with one another. This is accomplished by pressing the balls together from the back of the rack towards the apex ball, and then lifting and removing the rack from the playing area. The placement of the balls for a legal rack is that the black 8 ball is placed in the centre, while the two lower corners must be a stripe and a solid. The white cue ball is placed anywhere the breaker desires inside the "kitchen". One player then elects to break by hitting the white cue ball into the collection of balls.

After the break, 4 possibilities exist:

1. No balls fall into pockets: It becomes the other player's turn. The 2nd player then proceeds to target either stripe or solid depending on their preference: if they are successful in pocketing at least 1 ball of stripe or solid, then that becomes their target group for the remainder of the game. If unsuccessful, play reverts to player 1 and so on until one of the players is successful in knocking in a ball and can claim stripes or solids.
2. Some balls fall into a pocket: The player continues. The player has the choice to then target either stripe or solid. Should the player successfully knock one of these into a pocket on their next shot, this becomes their target group for the remainder of the game. The opposite group of balls becomes the target group of the 2nd player. If the player fails to pocket an additional ball after the break shot, then proceed as per (1) above where the 2nd player can then shoot to claim stripes or solids.
3. The black 8 ball falls into a pocket on the break: This results in an automatic win for the breaker.
4. The white cue ball falls into a pocket: This is a 'scratch'. The 2nd player can then place the cue ball anywhere on the playing area and proceed to try and knock in a ball to claim stripes or solids.

Once players have assumed a target group, their objective is to pocket all their balls, and finally the black 8 ball, to win. Players continue to shoot so long as they pocket at least one ball of their own group on each shot. If a player misses, it becomes the turn of the other player.

If either player scratches at any point (i.e. knocks the white cue ball into a pocket) the opponent has "ball-in-hand" on their next shot and can place the ball at any place on the table to take an easier shot.

To Win:

Any of the following circumstances results in a game win:

1. A player legally pockets the black 8 ball into a designated pocket after all their object balls have been pocketed.
2. The opposing player illegally pockets the black 8 ball (e.g. before clearing all of his object balls, does so on the same shot as the last such object ball, or it falls into a pocket other than the one that was designated).
3. The opposing player commits any foul, including scratching the white cue ball into a pocket, or knocking it off the table, during the same turn that the black 8 ball is pocketed. A scratch or foul is not a loss of the game if the black 8 ball is not pocketed or jumped from the table.
4. The opposing player knocks the black 8 ball off the table.

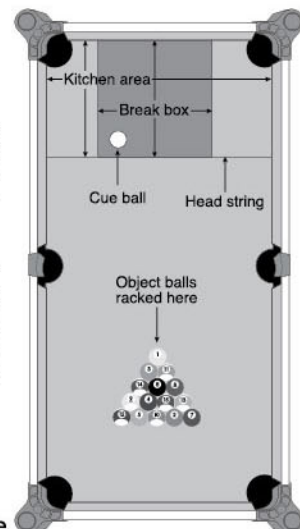

SLIDE HOCKEY / GAME RULES

Object of the Game: Score the most goals!

Set Up and Game Play:

1. The fan on the underside of the table should be turned on before play begins.
2. The youngest player gets the first possession of the puck, and proceeds to place the red puck in their zone and tries to score on their opponent.
3. Scoring is achieved by knocking the puck with your red pusher into your opponent's goal.
4. A player cannot touch or strike the puck with any part of their body or with any object other than the pusher. Doing so causes a foul and the other player is given possession of the puck in their zone.

5. When the puck breaks the horizontal plane inside the goal, a point is counted.
6. The first player to score 9 pints by shooting the puck into their opponent's goal, wins the game.
7. After each game, players change sides of the air hockey table before beginning the next game.
8. After you have finished playing, the fan should be turned off.

To Win:

The first player to score 9 points by shooting the puck into their opponent's goal, wins the game.